



**ENTERPRISE ARCHITECT**

User Guide Series

# **Automotive Open System Architecture (AUTOSAR)**

Author: Sparx Systems

Date: 2025-09-02

Version: 17.1

CREATED WITH  **ENTERPRISE  
ARCHITECT**

# Table of Contents

Automotive Open System Architecture (AUTOSAR) .....	3
Diagram Types .....	5
AUTOSAR Type Definition Diagram .....	6
AUTOSAR Diagram .....	7
AUTOSAR Behavior Diagram .....	8
Toolbox Pages .....	9
AUTOSAR Data Modeling Toolbox Page .....	10
The AUTOSAR Components and Ports Toolbox Page .....	12
AUTOSAR Behavior Toolbox Page .....	13
Support for AUTOSAR Data Types .....	15
VFB Models .....	20

# Automotive Open System Architecture (AUTOSAR)

The Automotive Open System Architecture (AUTOSAR) UML 2.5 Profile helps you develop AUTOSAR models within Enterprise Architect.

*"AUTOSAR is an architecture and modeling language developed by a global partnership of automotive interested parties that set out to create and establish an open and standardized software architecture for automotive electronic control units (ECUs).*

*AUTOSAR provides a set of specifications that describe basic software modules, define application interfaces and build a common development methodology based on standardized exchange format. Basic software modules made available by the AUTOSAR layered software architecture can be used in defining vehicles of different manufacturers and electronic components of different suppliers, thereby reducing expenditures for research and development and mastering the growing complexity of automotive electronic and software architectures."*

(This description is derived from the Wikipedia entry for AUTOSAR.)

## Accessing the Technology

The AUTOSAR UML Profile is provided within the Enterprise Architect installer. To ensure that it is activated, select the 'Specialize > Technologies > Manage Technology' ribbon option and scroll down the 'Technology' column to 'LieberLieber AUTOSAR Engineer'. Make sure the 'Enabled' check box against this entry is selected.

## Features

Feature	Description
AUTOSAR Support	Support for the AUTOSAR VFB 4 modeling language (such as component types, interfaces and runnables) by a UML 2.5 Profile.
Data Types	<p>You are able to define these different data types for usage with your AUTOSAR models:</p> <ul style="list-style-type: none"> <li>• Generic Base Types</li> <li>• Data Types <ul style="list-style-type: none"> <li>- Values</li> <li>- Arrays</li> <li>- Data Structures</li> </ul> </li> </ul> <p>Typically, such data type definitions are stored in a global library inside the Enterprise Architect model. For Component Interfaces it is also possible to store these elements together with the AUTOSAR components (such as in a structural elements folder as part of an abstraction level Package structure).</p>
Diagram Types	<p>The Enterprise Architect diagram creation facilities support the creation of these types of AUTOSAR diagram:</p> <ul style="list-style-type: none"> <li>• AUTOSAR Type Definition diagram</li> <li>• AUTOSAR diagram</li> <li>• AUTOSAR Behavior diagram</li> </ul>
Example Model	The Enterprise Architect Example model contains an example of an AUTOSAR model.
	AUTOSAR elements and connectors can be easily and quickly created using the

Object Creation	AUTOSAR Toolbox pages and the Quick Linker.
Port Type Definition	User modeling support for Port Type definition; the name, type and direction are automatically set on a new connected Port.
Mixed Modeling	You can perform mixed modeling with AUTOSAR, UML and SysML models in the same repository.
Virtual Functional Bus Modeling	A Virtual Functional Bus (VFB) is a communication mechanism that enables a composition of interconnected Components to interact with each other. AUTOSAR helps you to model such mechanisms.

# Diagram Types

AUTOSAR has three different diagram types:

- AUTOSAR Type Definition Diagram
- AUTOSAR Diagram
- AUTOSAR Behavior Diagram

## Set the AUTOSAR Perspective

When creating diagrams and structures, if AUTOSAR is not shown in the 'Type' or 'Perspective' field, click on the  icon in the top right of the screen and select the 'Systems Engineering > AUTOSAR' perspective.

## Create a New Diagram In AUTOSAR

To create diagrams for AUTOSAR, use the Enterprise Architect functionality to add a new diagram to a Package. That is:

1. Right click on the required parent Package.
2. Select the 'New Diagram' option.
3. On the 'Diagram Builder' tab page of the 'Model Builder' dialog, type a name for the diagram in the 'Diagram' field.
4. Click on the  icon and select the perspective 'Systems Engineering > AUTOSAR'.
5. In the 'Select From' panel, click on the 'LieberLieber Autosar Engineer' option.
6. In the 'Diagram Types' panel, click on the required type of diagram.
7. Click on the 'Create Diagram' button.

When you open an AUTOSAR diagram the appropriate AUTOSAR Toolbox page for the diagram type is automatically opened. The Toolbox page contains all the necessary elements and connectors to populate the diagram. For more information on these Toolbox pages, see the *Toolboxes* Help topic.

# AUTOSAR Type Definition Diagram

You use the AUTOSAR Type Definition diagram (atdd) to define data types and interface types. This is similar to creating Classes before being able to create instances (Objects).

Example:

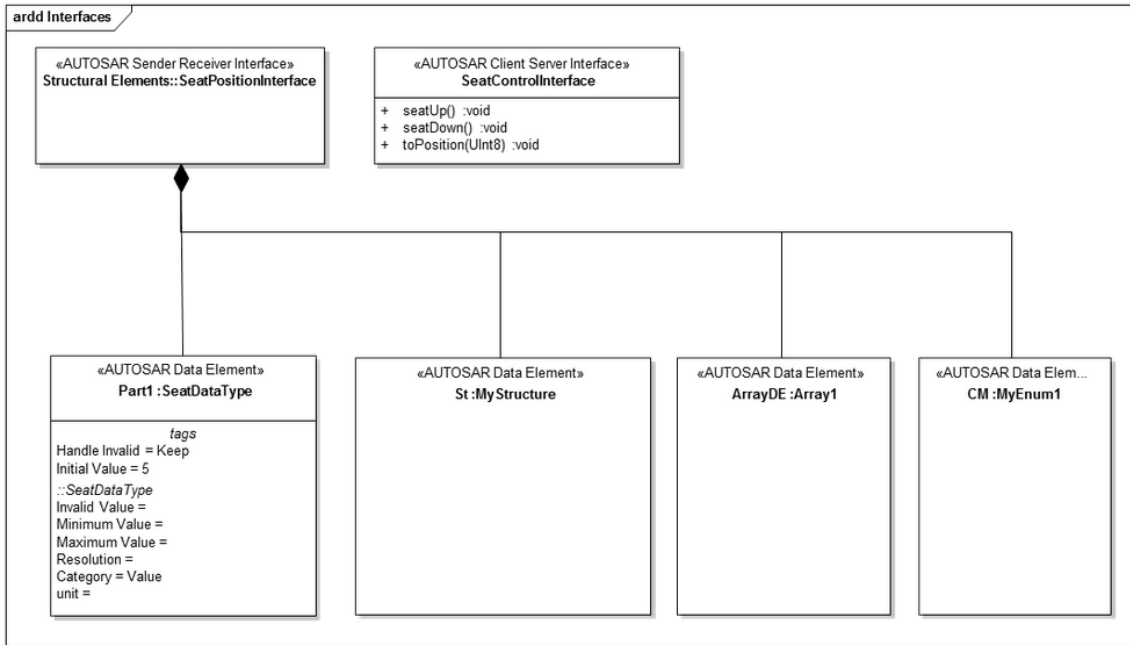

# AUTOSAR Diagram

All structural Virtual Functional Bus (VFB) models are modeled with the AUTOSAR diagram type, showing AUTOSAR components with Ports and interconnections. (Also see the *VFB Models* Help topic.)

Example:

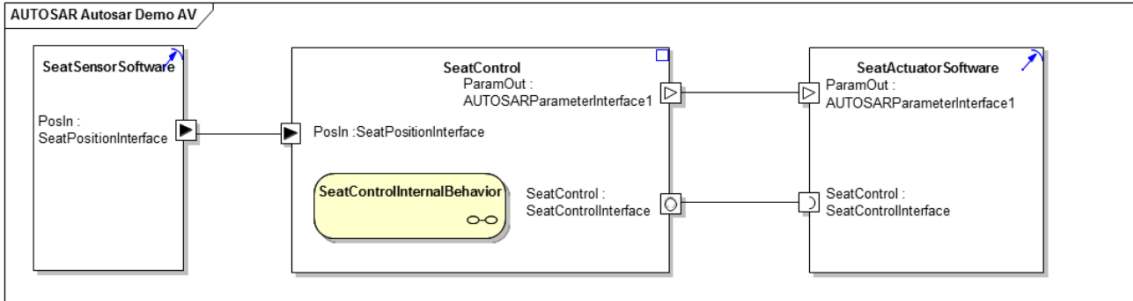

# AUTOSAR Behavior Diagram

The AUTOSAR Behavior Diagram (arbeh) is used to model behavior for AUTOSAR Components. Typically, the diagram shows Runnables, Inter-Runnable Variables, and Triggers.

Example:

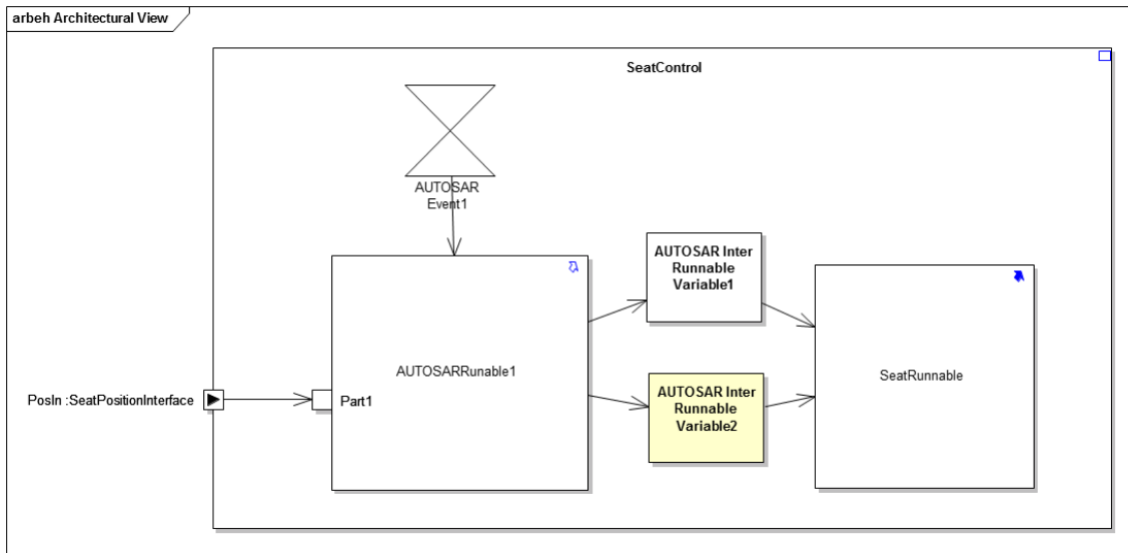

## Toolbox Pages

AUTOSAR in Enterprise Architect has three Toolbox pages for creating elements and connectors required to develop AUTOSAR models:

- AUTOSAR Data Modeling
- AUTOSAR Components and Ports
- AUTOSAR Behavior

# AUTOSAR Data Modeling Toolbox Page

The AUTOSAR Data Modeling Toolbox page contains the elements required to model AUTOSAR data and interface types.

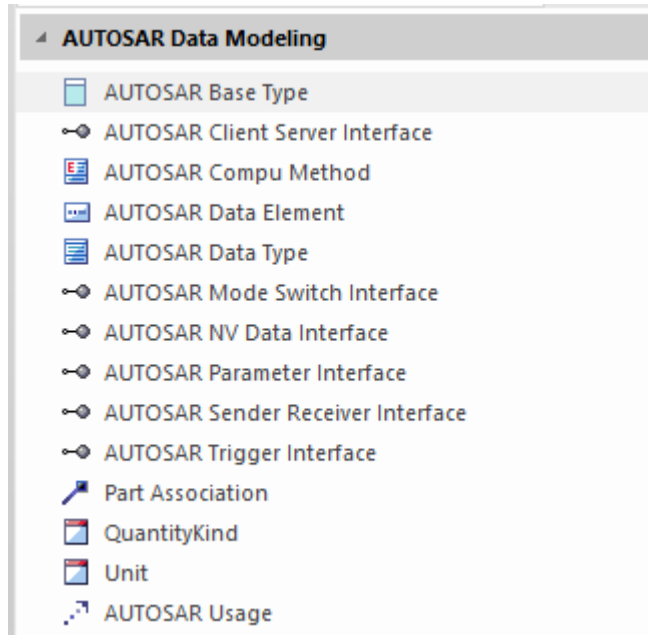

## AUTOSAR Data Modeling Model Elements

Icon	Description
AUTOSAR Base Type	Used to create AUTOSAR base types, for example: uint8 or uint16.
AUTOSAR Client-Server Interface	Used to define a Client-Server Interface, which is used as the Port-Type for a Client-Server Port.
AUTOSAR Compu Method	Used to define an AUTOSAR Compu Method.
AUTOSAR Data Element	Used to create an instance (Property) of an AUTOSAR Data Type. You can use this element to model internal data attributes of AUTOSAR Data Elements.
AUTOSAR Data Type	Used to define AUTOSAR data types such as Values, Arrays, Structures and Type References. You can set the type using the element Tagged Values.
AUTOSAR Mode Switch Interface	Used to define a Mode Switch Interface, which is used for a Mode Switch Port.
AUTOSAR NV Data Interface	Used to define a Non-Volatile Data Interface, which is used for an NV Data Port
AUTOSAR Parameter Interface	Used to define a Parameter Interface, which is used for a Parameter Port.

AUTOSAR Sender Receiver Interface	Used to define a Sender-Receiver-Interface, which is used for a Sender Receiver Port.
AUTOSAR Trigger Interface	Used to define a Trigger-Interface, which is used for a Trigger Port.
Part Association	Used to define an 'is-part-of' relationship between interface types and data elements.
Quantity Kind	Defines a quantity kind, a physical dimension according to the SysML standard.
Unit	Used to define a physical unit according to the SysML standard.
AUTOSAR Usage	Used to express dependencies between data type elements. See the <i>Support for AUTOSAR Data Types</i> Help topic for information on when to use this connector.

## The AUTOSAR Components and Ports Toolbox Page

The AUTOSAR Components and Ports Toolbox page contains the elements required to model AUTOSAR components with Ports and interconnections. You can use the elements' Tagged Values to set the Port direction and whether the Port is a service Port.

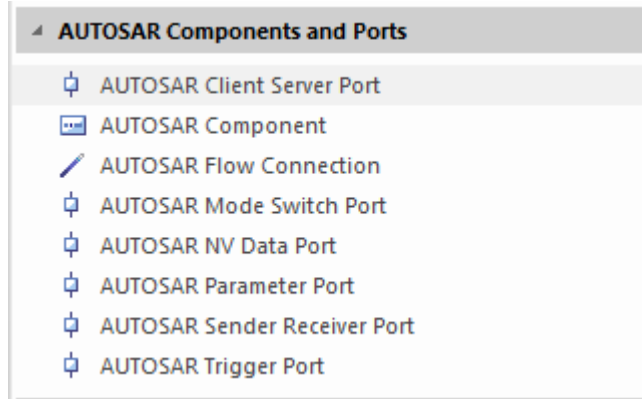

### AUTOSAR Components and Ports Model Elements

Icon	Description
AUTOSAR Component	Used to define an AUTOSAR Component. The Component type is set in a Tagged Value on the Component.
AUTOSAR Client Server Port	Used to define a Client-Server Port for a Component.
AUTOSAR Sender Receiver Port	Used to define a Sender-Receiver Port for a Component.
AUTOSAR Mode Switch Port	Used to define a Mode Switch Port for a Component.
AUTOSAR NV Data Port	Used to define a Non-Volatile Data Port for a Component.
AUTOSAR Parameter Port	Used to define a Parameter Port for a Component.
AUTOSAR Trigger Port	Used to define a Trigger Port for a Component.
AUTOSAR Flow Connection	Used to create a Flow connector between two Ports.

# AUTOSAR Behavior Toolbox Page

The AUTOSAR Behavior Toolbox page provides the elements required to model the internal behavior of AUTOSAR components (such as Runnables and Inter-Runnable Variables).

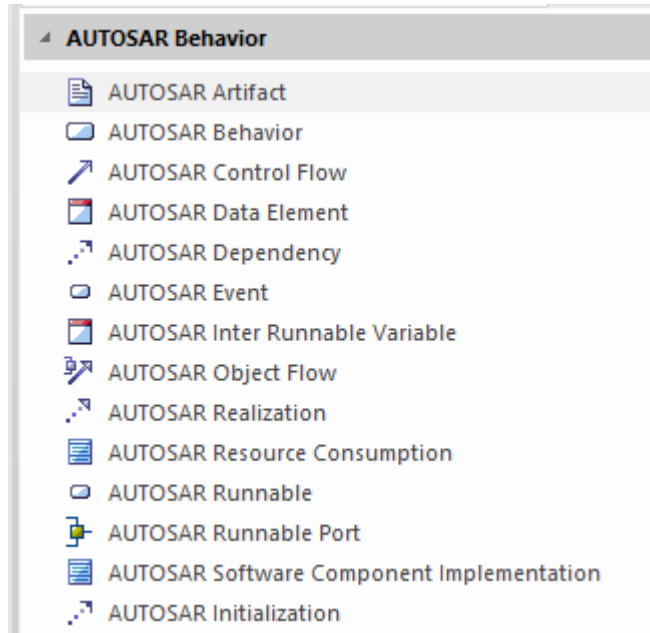

## AUTOSAR Behavior Model Elements

Icon	Description
AUTOSAR Artifact	Used to define an Artifact such as a .h or .c file in an AUTOSAR model.
AUTOSAR Behavior Container	Used to create a container of all behavior elements in an AUTOSAR Component. This element is based on the Enterprise Architect Structured Activity and you can use the functionality of the Composite diagram in Enterprise Architect to enable double-click navigation to the sub-diagram.
AUTOSAR Control Flow	Used to define a connector representing the flow of control from an AUTOSAR Event to an AUTOSAR Runnable.
AUTOSAR Data Element	Not used. Reserved for future extensions.
AUTOSAR Dependency	Used to create a connector representing the dependency of one model element on another.
AUTOSAR Event	Used to define an AUTOSAR element event; for example, a time event to start a Runnable.
AUTOSAR Inter Runnable Variable	Used to define an Inter-Runnable Variable.
AUTOSAR Object Flow	Used to create a connector between Runnables and Inter Runnable Variables or Component Ports and AUTOSAR Runnable Ports.

AUTOSAR Realization	Used to create a connector that expresses the realization of a Runnable or a Component. It is used to connect Runnables and/or Components and AUTOSAR Artifacts.
AUTOSAR Runnable	Used to define a Runnable as part of the Component Behavior.
AUTOSAR Runnable Port	Used to define a Runnable Port as an interface of a Runnable. Runnable Ports are connected by an AUTOSAR Object Flow connector to an AUTOSAR Component Port.
AUTOSAR Software Component Implementation	Used to create an element that represents a Software Component Implementation.
AUTOSAR Initialization	Used to define a connector that specifies complex data type initializations.

# Support for AUTOSAR Data Types

You can define different data types for use in developing AUTOSAR diagrams within Enterprise Architect. These data types are supported:

- Generic Base Types
- Data Types
  - Values
  - Arrays
  - Data Structures
- Port Type Definition

Typically, such data type definitions are stored in a global library inside the Enterprise Architect model. For Component Interfaces it is also possible to store these elements together with the AUTOSAR components - for example, in a structural elements folder as part of an abstraction level Package structure, as illustrated by this diagram.

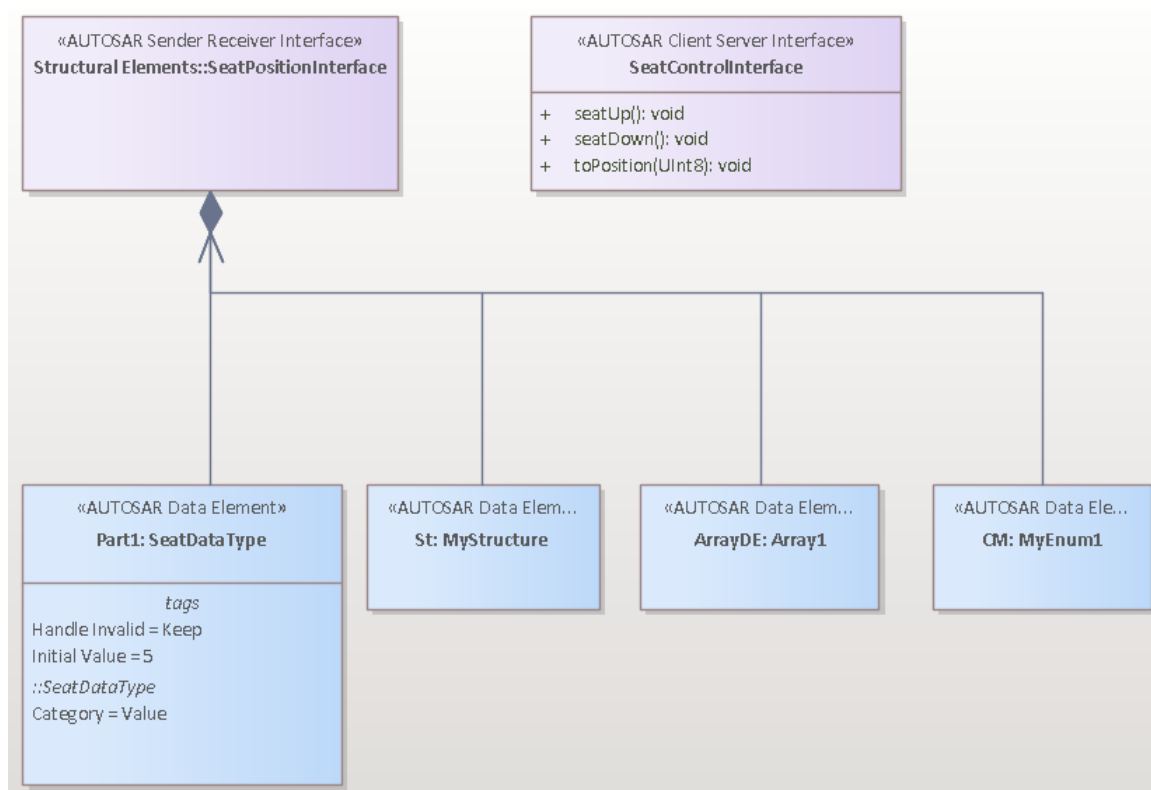

## Generic Base Types

In AUTOSAR, generic base types are used to define base primitive data types such as 'int' and 'double', as illustrated in this diagram:

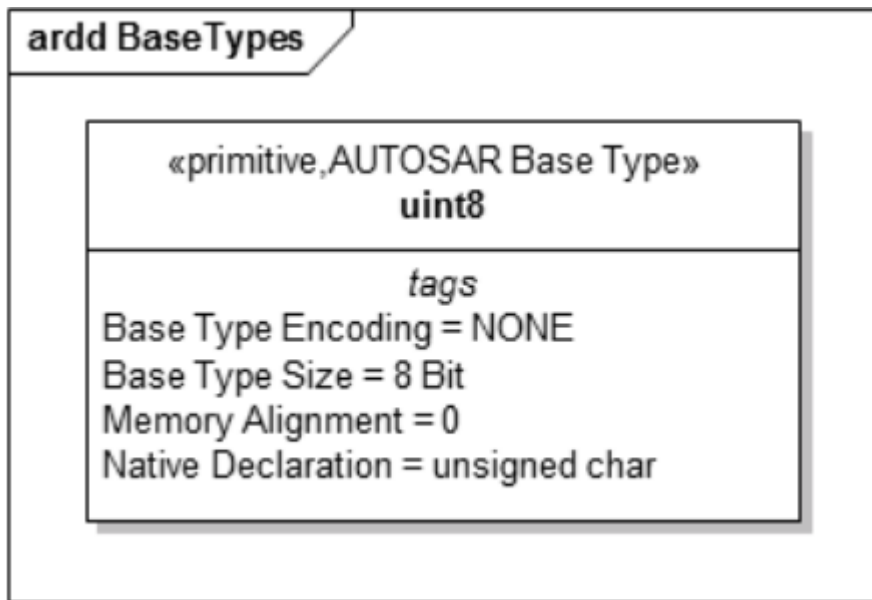

## Data Types

AUTOSAR Data Types are elements commonly used to specify Values, Data Structures and Arrays. The Data Type element has a set of Tagged Values in which you define additional properties. We recommend that you have the Properties window open so that you can expand the AUTOSAR segment and easily access the Tagged Values of the element.

- Values are modeled using an AUTOSAR Data Type element with the 'Category' Tagged Value set to 'Value'; this diagram shows a Value definition - the Value 'UInt8' has an AUTOSAR Usage dependency to an AUTOSAR base-type to specify that the value is based on a 'uint8' SW-BASE-TYPE

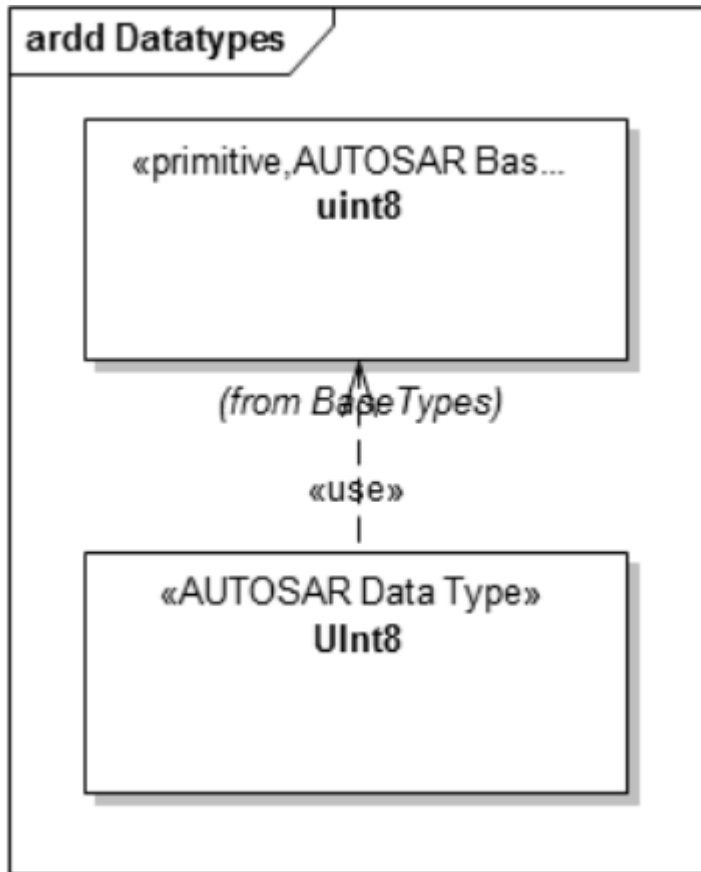

- Data Structures - Data Structures are modeled using an AUTOSAR Data Type element with the 'Category' Tagged Value set to 'Structure'; elements of the structure are modeled as AUTOSAR Data elements (instances of AUTOSAR Data Type elements), as illustrated in this diagram:

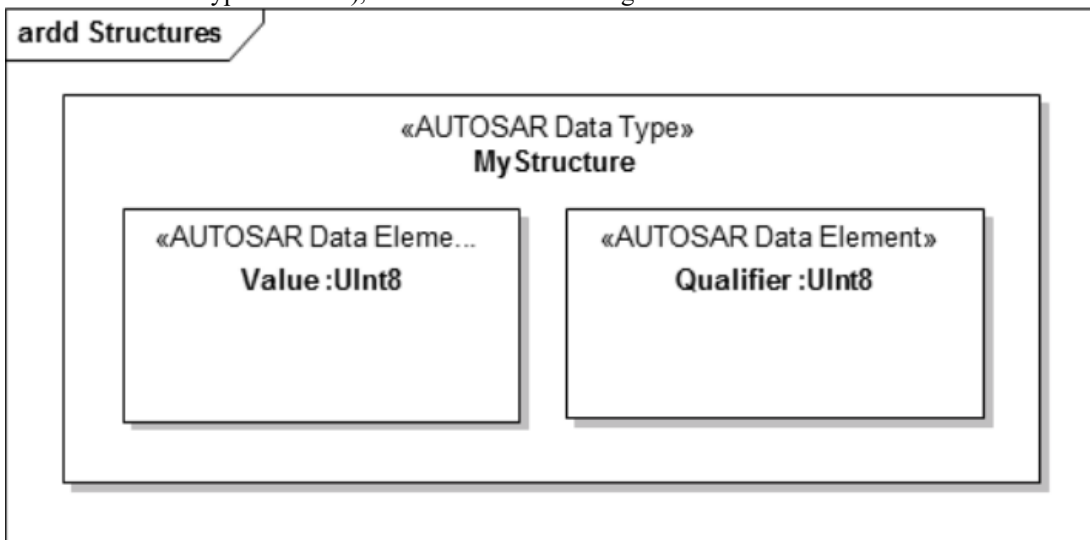

- Arrays are modeled using an AUTOSAR Data Type element with the 'Category' Tagged Value set to 'Array'; to specify which kind of data type the array elements have, an instance of an AUTOSAR Data Type element (an AUTOSAR Data element) is embedded in the Data Type element, and the array size is specified by the 'Multiplicity' setting of the embedded Data element - this example shows how an Array with size 8 of type UInt8 is defined:

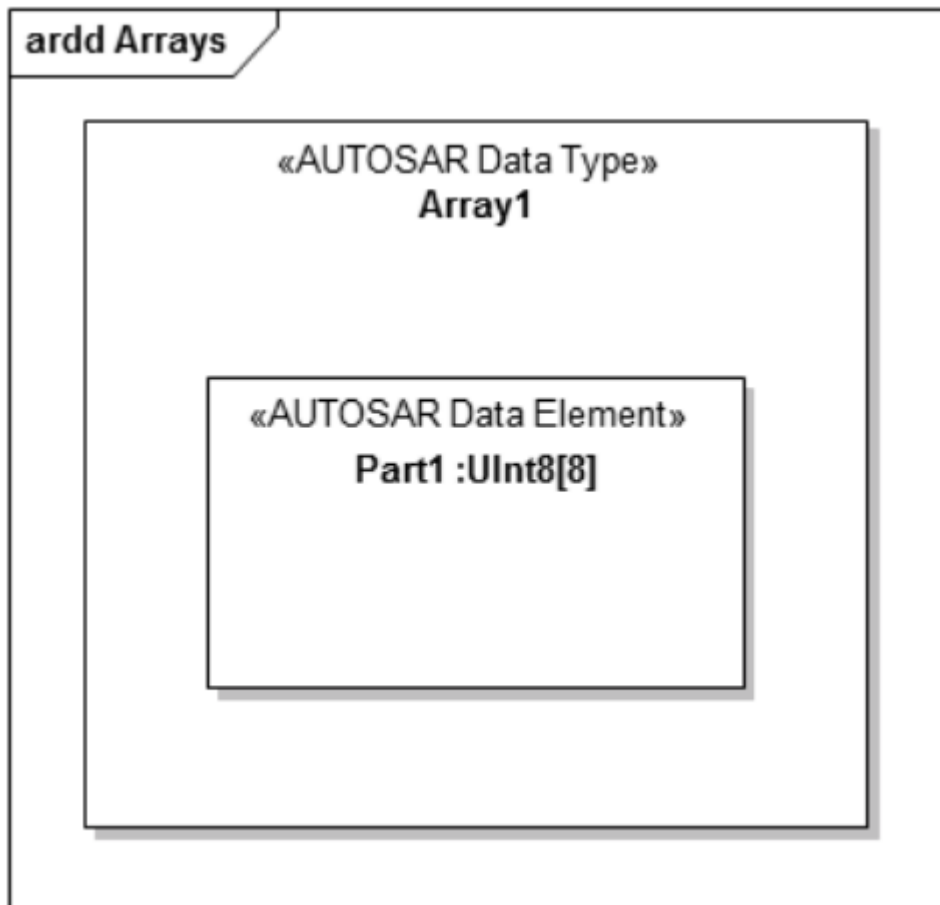

### Port Type Definition

Port type definitions are modeled with Interface elements (provided by the AUTOSAR Data Modeling Toolbox page). For each AUTOSAR Port type a matching Interface element is defined. This diagram shows how a Sender-Receiver Port type and a Client-Server Port type are defined with AUTOSAR.

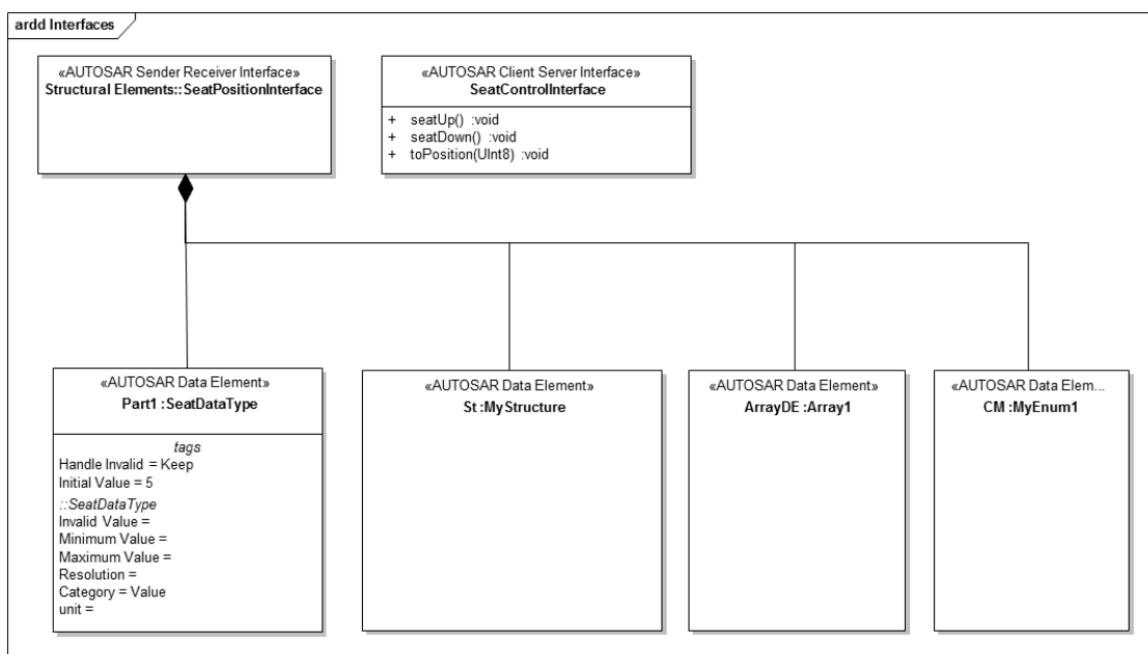

- For Client-Server Interfaces, use the Enterprise Architect functionality to define Operations
- For Sender-Receiver Interfaces, define the Data elements explicitly and create Part Association Connectors (black diamond head) to specify that the data elements are part of the Sender-Receiver interface

## VFB Models

A Virtual Functional Bus (VFB) is a communication mechanism that enables a composition of interconnected Components to interact with each other. AUTOSAR helps you to model such mechanisms.

To create a Virtual Functional Bus (VFB) model, you start by creating the Components as instances (part-elements) of AUTOSAR Component classifier elements, in an AUTOSAR diagram. If no Component classifiers are available, first define Data Types using an AUTOSAR Type Definition diagram.

To create a new Component:

1. Onto the diagram, either:
  - Drag and drop an AUTOSAR Component icon from the 'AUTOSAR Components and Ports' Toolbox page or
  - Ctrl+drag and drop an AUTOSAR Component classifier from the Browser window and, on the 'Paste <classifier name>' dialog, in the 'Drop as' field choose the 'Instance (AUTOSAR Component)' option
2. On the 'Element' tab of the Properties window for the Component, type the element's name.
3. Also on the 'Element' tab, expand the 'AUTOSAR Component' segment and set the component characteristic in the 'Characteristic' Tagged Value of the component. You can select from the component types defined by the AUTOSAR VFB specification.

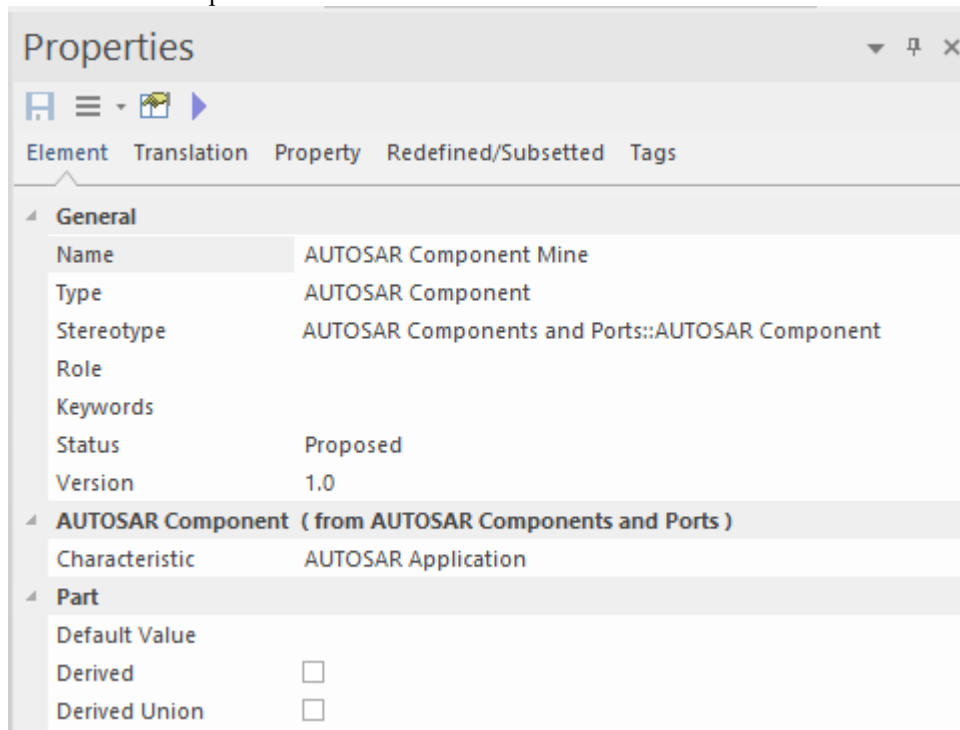

4. After creating the Component elements, go on to adding interfaces, as explained in the next section.

## Adding Interfaces

To add interfaces to Components, select from the various AUTOSAR Port elements available in the 'AUTOSAR Components and Ports' Toolbox page. Set the element name and property type in the Properties window for the Port. Use the element's Tagged Values to set the direction and whether the Port is a Service Port.

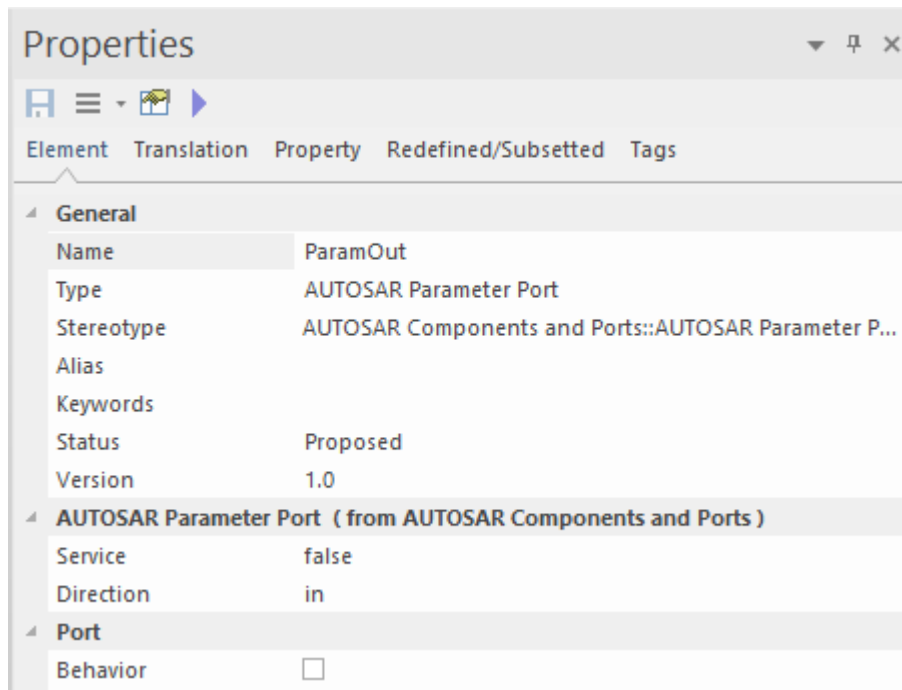

### Adding Connections

To connect two Ports, use the AUTOSAR Flow Connection connector. You can use the Enterprise Architect Quick Linker to connect the two Ports or to create a new Port and a connection in one step, by creating a connector between an existing Port and a Component. AUTOSAR will assist you by automatically setting the name, Port type and direction of the new Port when these are undefined.

### Port Direction Determination

To be able to determine the Port direction correctly, you must add a UML Compose or a SysML Part Association connector (black diamond) to define the hierarchy of your Components. These will define the relationship 'this Component is a sub-element of that Component' and AUTOSAR can set the direction correctly. This diagram is an example of such a Component hierarchy specification (the Decomposition View):

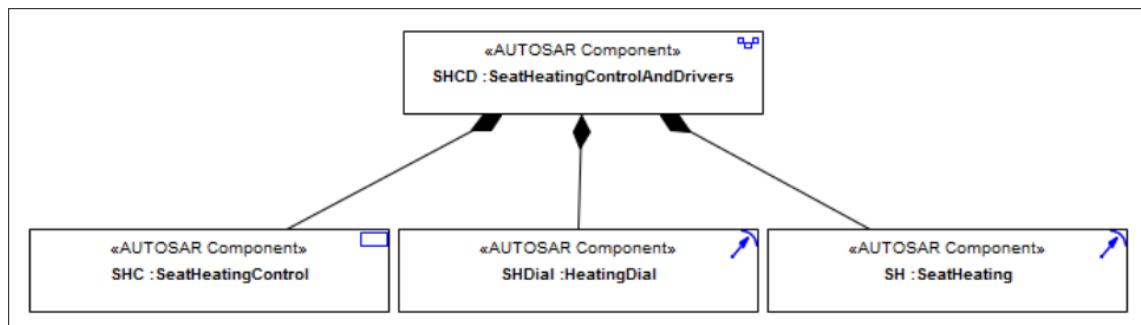

### Result

This illustration is of an AUTOSAR diagram with Components, Interfaces and Interface Connections (the Architectural View). The option 'Show Element Stereotypes' is disabled for the diagram.

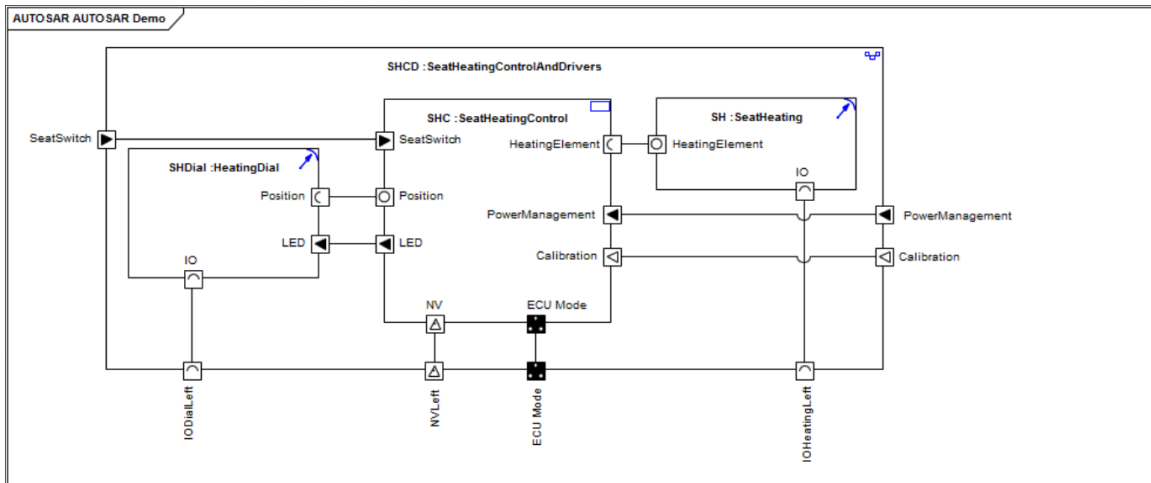

## Behavior Modeling

The behavior of AUTOSAR Components is modeled on an AUTOSAR Behavior diagram. After you have created an AUTOSAR Component on an AUTOSAR diagram, you can add an AUTOSAR Behavior element as a container for the behavior model.

1. Drag an AUTOSAR Behavior element onto your AUTOSAR diagram.
2. In the Properties window, name the element.
3. Add a Part Association connector from the Behavior element to the AUTOSAR Component element, to express that the Behavior element is part of the Component.
4. Right-click on the Behavior element and select the 'New Child Diagram > New Diagram' option, and create the AUTOSAR Behavior sub-diagram.
5. Model the internal behavior using Runnables and Inter-Runnable-Variables on the AUTOSAR Behavior diagram.

Each AUTOSAR Behavior element has a Tagged Value in which you set whether or not the element can be instantiated multiple times.

If a Runnable can be invoked concurrently, you can use another Tagged Value to set whether this happens or not. If a Runnable can be invoked concurrently, the arrow symbol in the top right corner of the element is filled blue; otherwise it is not filled.

